

# CCT-90-3

## FICHE TECHNIQUE / SPEC SHEET

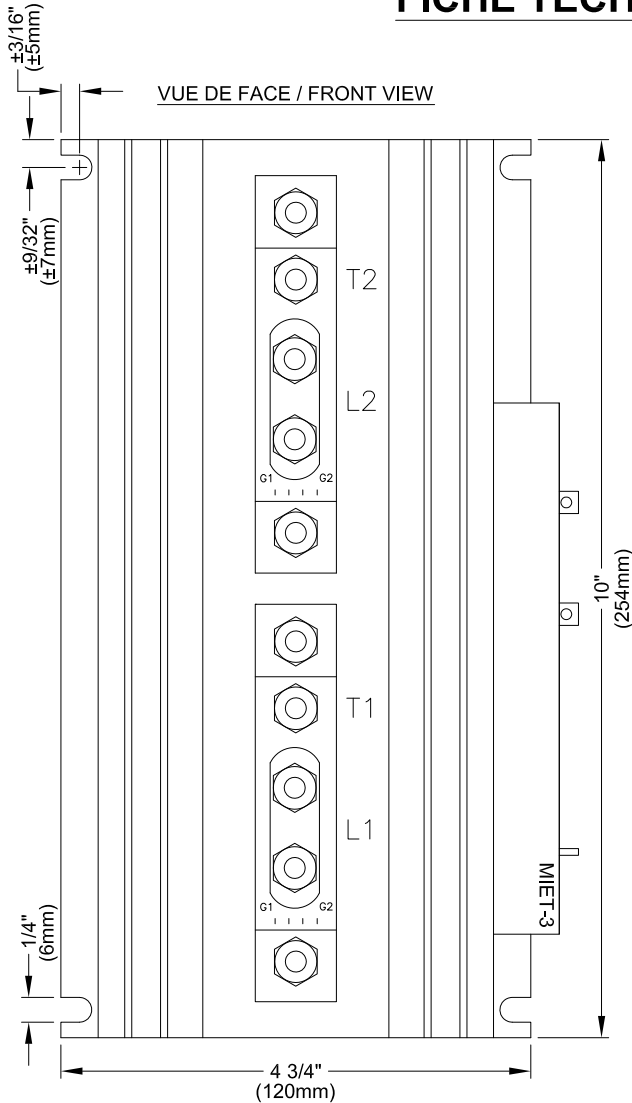

**SPECIFICATIONS:**

**MODULES DE PUISSANCE / POWER MODULES :** TYPE THYRISTORS  
**RADIATEUR / HEATSINK :** TYPE MS-15170  
**CONTRÔLE MODULANT / MODULATING CONTROL :** MIET-3  
**SIGNAL DE CONTRÔLE / CONTROL SIGNAL :** 3-32Vdc, 24Vac  
**MODÈLE / MODEL :** CCT-90-3  
**COURANT / AMPERAGE :** 90A  
**VOLTAGE :** 48VAC - 600VAC, 3 PHASES (2 LEGS)  
**OPÉRATION PAR PASSAGE À ZÉRO / ZERO-CROSS OPERATION**



DIRECTION D'AIR /  
AIR FLOW

L1 & L2 = LIGNES / LINES  
T1 & T2 = CHARGES / LOADS

VUE DE CÔTÉ / SIDE VIEW

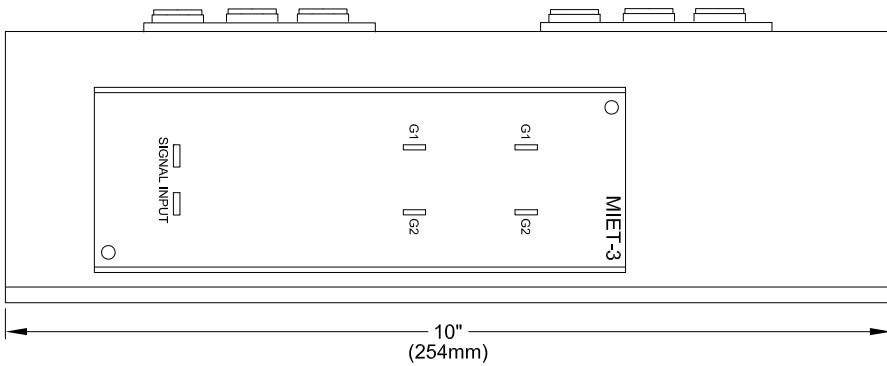

VUE DU BAS / BOTTOM VIEW

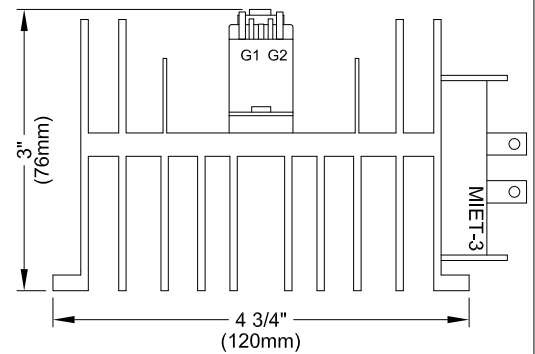

**CRISTAL**

2025 LAVOISIER #135  
 QUEBEC, QC, CANADA  
 G1N 4L6  
 TEL: 1-800-681-9590  
 FAX: 1-418-681-7393  
[www.cristalcontrols.com](http://www.cristalcontrols.com)



C US  
 CAN/CSA-C22.2 NO. 14-M95  
 -APPAREILLAGE INDUSTRIEL DE COMMANDE  
 UL Std No. 508  
 -INDUSTRIAL CONTROL EQUIPMENT

- PROPOSITION
- APPROBATION
- INFORMATION

Préparé par: LT, Vérifié par: PC

DESSIN / DRAWING :

CCT-90-3

DATE :

MARS 2012