

# CCT-30-3Y

## FICHE TECHNIQUE / SPEC SHEET

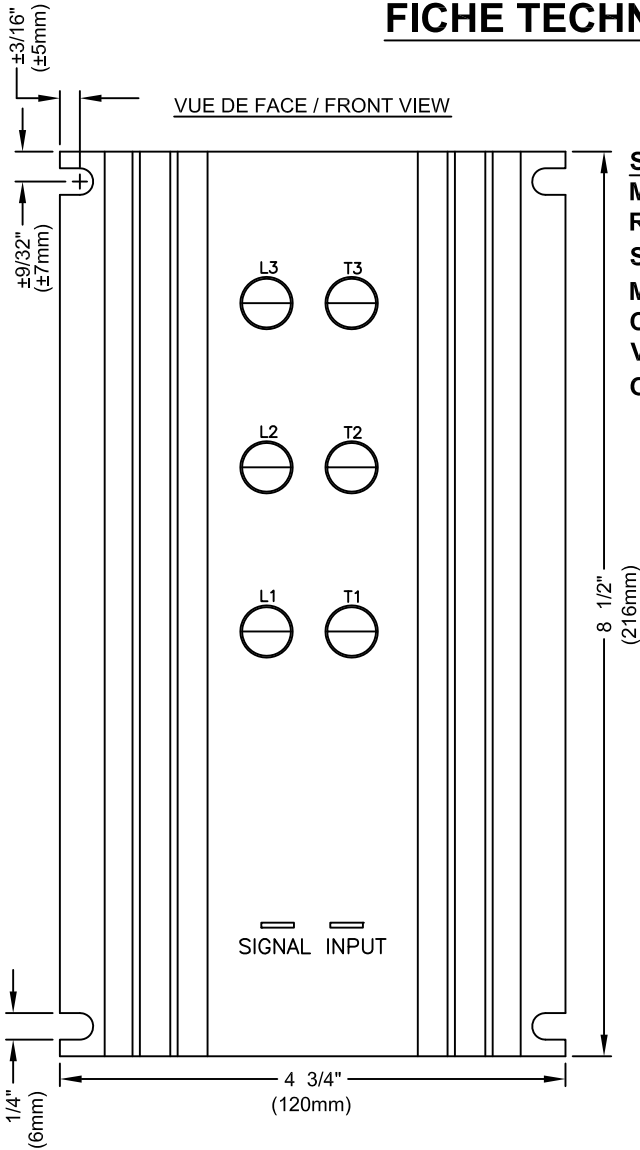

**SPECIFICATIONS:**

**MODULE DE PUISSANCE / POWER MODULE :** TYPE TRIAC

**RADIATEUR / HEATSINK :** TYPE MS-15170

**SIGNAL DE CONTRÔLE / CONTROL SIGNAL :** 3-32Vdc, 24Vdc, 24Vac

**MODÈLE / MODEL :** CCT-30-3Y

**COURANT / AMPERAGE :** 30A

**VOLTAGE :** 48VAC - 600VAC, 3 PHASES (3 LEGS), 50-60 Hz

**OPÉRATION PAR PASSAGE À ZÉRO / ZERO-CROSS OPERATION**

↑  
DIRECTION D'AIR /  
AIR FLOW

L1, L2 & L3 = LIGNES / LINES  
T1, T2 & T3 = CHARGES / LOADS

**VUE DE CÔTÉ / SIDE VIEW**

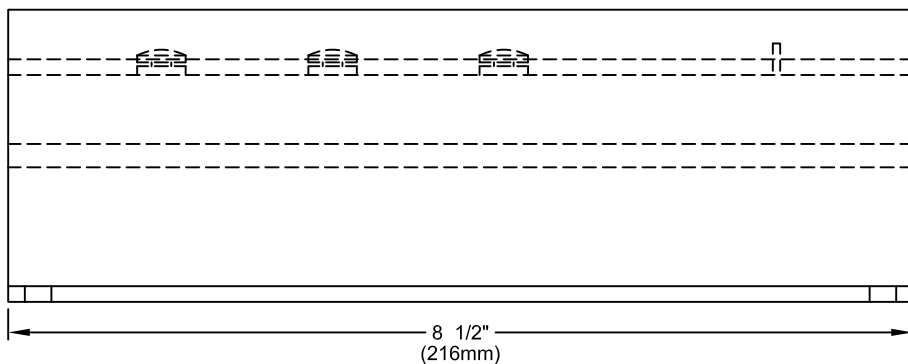

**VUE DU BAS / BOTTOM VIEW**

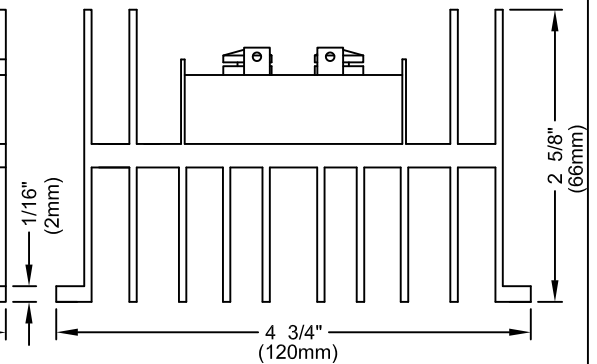

**CRISTAL**

2025 LAVOISIER #135  
QUEBEC, QC, CANADA  
G1N 4L6  
TEL: 1-418-681-9590  
FAX: 1-418-681-7393  
[www.cristalcontrols.com](http://www.cristalcontrols.com)



CAN/CSA-C22.2 NO. 14-M95  
-APPAREILLAGE INDUSTRIEL DE COMMANDE  
UL Std No. 508  
-INDUSTRIAL CONTROL EQUIPMENT

- PROPOSITION
- APPROBATION
- INFORMATION

Préparé par: LT, Vérifié par: PC

DESSIN / DRAWING :

CCT-30-3Y

DATE :

MARS 2012